

Zebra® EZ320™
Mobile Printer

User Guide



Table of Contents

Proprietary Statements	4
Document Conventions	6
Introduction to the EZ320	7
Unpacking and Inspection	7
Reporting Damage	7
Getting Ready to Print	10
Battery	10
Installing and Removing the Battery	10
EZ320 Single Bay Charger	14
Charger Safety	15
Loading the Media (80 mm)	16
60 mm Roll of Media	18
Media Black Bar Sensor	18
Operator Controls	19
Verify the Printer Is Working	21
Printing a Configuration Label	21
Connecting the Printer	21
Wireless Communications with Bluetooth™	23
Bluetooth Networking Overview	23
About Bluetooth Security	23
Carrying the Printer	25
Belt Strap	25
Nylon Soft Case	26
Preventive Maintenance	27
Extending Battery Life	27
General Cleaning Instructions	28
Troubleshooting	30
Interpreting Indicators	30
Troubleshooting Topics	30
Resetting an EZ320 Printer	32
Determining Your Printer Version	32
Troubleshooting Tests	33
Printing a Configuration Label	33
Communications Diagnostics	33
Calling Technical Support	34
Specifications	38
Printing Specifications	38
Memory and Communications Specifications, EZ320	38
Media Specifications	39
Font and Bar Code Specifications for EZ320	40
USB Communications Port	43
Physical, Environmental and Electrical Specifications	43
EZ320 Accessories	45
Appendix A	45
Interface Cables	45
USB Cable	45
More Interface Cables	45
Appendix B	45

continued

Maintenance Supplies.....	45
Appendix C	46
Media Supplies.....	46
EZ320 Media.....	46
Appendix D.....	47
Product Support.....	47
Product Support Contacts	48
Appendix E.....	49
Product Documentation.....	49
Index.....	50
Patent Numbers	51

Proprietary Statements

This manual contains proprietary information of Zebra Technologies Corporation. It is intended solely for the information and use of parties operating and maintaining the equipment described herein. Such proprietary information may not be used, reproduced, or disclosed to any other parties for any other purpose without the expressed written permission of Zebra Technologies Corporation.

Product Improvements

Since continuous product improvement is a policy of Zebra Technologies Corporation, all specifications and signs are subject to change without notice.

NCC Warning

According to “Administrative Regulations on Low Power Radio Waves Radiated Devices” Without permission granted by the NCC, any company, enterprise, or user is not allowed to change frequency, enhance transmitting power or alter original characteristic as well as performance to an approved low power radio-frequency devices. The low power radio-frequency devices shall not influence aircraft security and interfere legal communications; If found, the user shall cease operating immediately until no interference is achieved. The said legal communications means radio communications is operated in compliance with the Telecommunications Act.

The low power radio-frequency devices must be susceptible with the interference from legal communications or ISM radio wave radiated devices.

“經型式認證合格之低功率射頻電機，非經許可，公司、商號或使用者均不得擅自變更頻率、加大功率或變更原設計之特性及功能。低功率射頻電機之使用不得影響飛航安全及干擾合法通信；經發現有干擾現象時，應立即停用，並改善至無干擾時方得繼續使用。前項合法通信，指依電信法規定作業之無線電通信。低功率射頻電機須忍受合法通信

工業、科學 醫療用電波輻射性電機設備之干擾”

Changes or modifications to this unit not expressly approved by Zebra Technologies Corporation could void the user’s authority to operate this equipment.

Agency Approvals and Regulatory Information

- Design certified by TUV
- EN60950: 2006 Safety Standard
- Taiwan NCC
- China CCC
- China SRRC

Liability Disclaimer

Inasmuch as every effort has been made to supply accurate information in this manual, Zebra Technologies Corporation is not liable for any erroneous information or omissions. Zebra Technologies Corporation reserves the right to correct any such errors and disclaims liability resulting therefrom.

No Liability for Consequential Damage

In no event shall Zebra Technologies Corporation or anyone else involved in the creation, production, or delivery of the accompanying product (including hardware and software) be liable for any damages whatsoever (including, without limitation, damages for loss of business profits, business interruption, loss of business information, or other pecuniary loss) arising out of the use of or the results of use of or inability to use such product, even if Zebra Technologies Corporation has been advised of the possibility of such damages. Because some states do not allow the exclusion of liability for consequential or incidental damages, the above limitation may not apply to you.

continued

Copyrights

The copyrights in this manual and the label print engine described therein are owned by Zebra Technologies Corporation. Unauthorized reproduction of this manual or the software in the label print engine may result in imprisonment of up to one year and fines of up to \$10,000 (17 U.S.C.506). Copyright violators may be subject to civil liability.

This product may contain ZPL®, ZPL II®, and ZebraLink™ programs; Element Energy Equalizer® Circuit; E3®; and AGFA fonts. Software © ZIH Corp. All rights reserved worldwide. ZebraLink and all product names and numbers are trademarks, and Zebra, the Zebra logo, ZPL, ZPL II, Element Energy Equalizer Circuit, and E3 Circuit are registered trademarks of ZIH Corp. All rights reserved worldwide.

Monotype®, Intellifont® and UFST® are trademarks of Monotype Imaging, Inc. registered in the United States Patent and Trademark Office and may be registered in certain jurisdictions.

Andy™, CG Palacio™, CG Century Schoolbook™, CG Triumvirate™, CG Times™, Monotype Kai™, Monotype Mincho™ and Monotype Sung™ are trademarks of Monotype Imaging, Inc. and may be registered in some jurisdictions.

HY Gothic Hangul™ is a trademark of Hanyang Systems, Inc.

Angsana™ is a trademark of Unity Progress Company (UPC) Limited.

Andale®, Arial®, Book Antiqua®, Corsiva®, Gill Sans®, Sorts® and Times New Roman® are trademarks of The Monotype Corporation registered in the United States Patent and Trademark Office and may be registered in certain jurisdictions.

Century Gothic™, Bookman Old Style™ and Century Schoolbook™ are trademarks of The Monotype Corporation and may be registered in certain jurisdictions.

HGPGothicB is a trademark of the Ricoh company, Ltd. and may be registered in some jurisdictions.

Univers™ is a trademark of Heidelberger Druckmaschinen AG, which may be registered in certain jurisdictions, exclusively licensed through Linotype Library GmbH, a wholly owned subsidiary of Heidelberger Druckmaschinen AG.

Futura® is a trademark of Bauer Types SA registered in the United States Patent and Trademark Office and may be registered in some jurisdictions.

TrueType® is a trademark of Apple Computer, Inc. registered in the United States Patent and Trademark Office and may be registered in certain jurisdictions.

All other product names are the property of their respective owners.

All other brand names, product names, or trademarks belong to their respective holders.

©2010 ZIH Corp.

Document Conventions

The following conventions are used throughout this document to convey certain information:

If you are viewing this guide online, click the underlined text to jump to a related Web site. Click on italic text (not underlined) to jump to that location in this manual.

Cautions, Important, and Note



Caution • Warns you of the potential for electrostatic discharge.



Caution • Warns you of a potential electric shock situation.



Caution • Warns you of a situation where excessive heat could cause a burn.



Caution • Advises you that failure to take or avoid a specific action could result in physical harm to you.



Caution • Advises you that failure to take or avoid a specific action could result in physical harm to the hardware.



Important • Advises you of information that is essential to complete a task.



Note • Indicates neutral or positive information that emphasizes or supplements important points of the main text.

Introduction to the EZ320

Thank you for choosing our Zebra® EZ320™ Mobile Printer. This rugged printer is sure to become a productive and efficient addition to your workplace thanks to its innovative design. Because it is made by Zebra Technologies, you're assured of world-class support for all of your bar code printers, software, and supplies.

- This user's guide gives you the information you will need to operate the EZ320 printer.
- The EZ320 printer uses the CPCL programming language. To create and print labels using the CPCL language, refer to the Mobile Printing Systems CPCL Programming Guide and our ZebraDesigner™ Pro and Zebra Set-up Utilities programs which are all available at www.zebra.com.

Unpacking and Inspection

Inspect the printer for possible shipping damage:

- Check all exterior surfaces for damage.
- Open the media cover (refer to "Loading the Media" in the Getting Ready to Print section) and inspect the media compartment for damage.

In case shipping is required, save the carton and all packing material.

Reporting Damage

If you discover shipping damage:

- Immediately notify and file a damage report with the shipping company. Zebra Technologies Corporation is not responsible for any damage incurred during shipment of the printer and will not cover the repair of this damage under its warranty policy.
- Keep the carton and all packing material for inspection.
- Notify your authorized Zebra re-seller.

Figure 1: EZ320 Overview

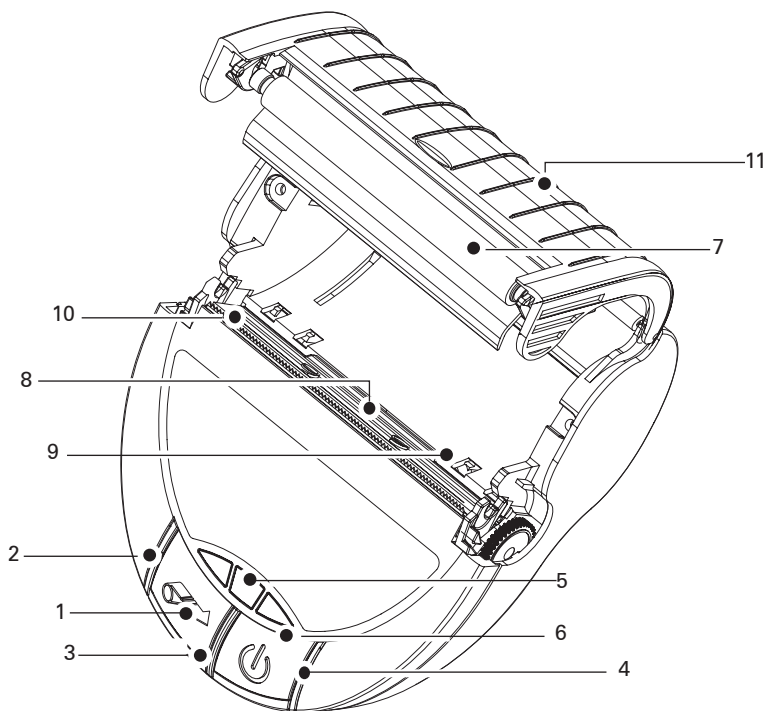

1. Paper Feed Button
2. Error Status Indicator
3. Bluetooth Indicator
4. Charge Indicator
5. Battery Status Indicator
6. Power Button
7. Platen
8. Printhead
9. Media/Black Bar Sensor
10. Tear Bar
11. Media Cover
12. USB Port
13. Battery Charging Receptacle

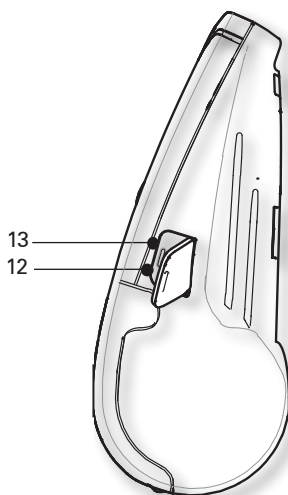

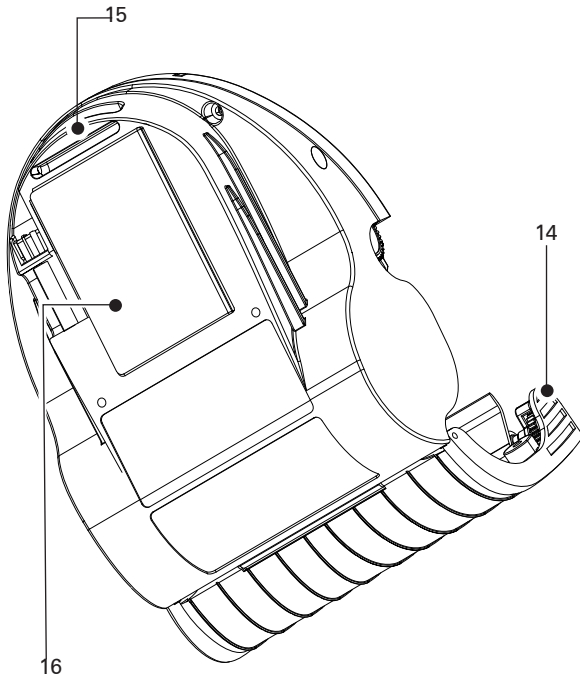

- 14. Media Cover Tab
- 15. Belt Strap Opening
- 16. Battery Pack

Getting Ready to Print

Battery

Installing and Removing the Battery



Important • Batteries are shipped partially charged. Remove any protective packaging from new battery packs prior to use.

1. Insert the battery into the printer as shown in Figure 2 using the outline of the battery to match the outline of the battery compartment.
2. Rock the battery into the printer as shown until it locks in place. When the battery is first installed, and the printer is turned on, the battery status indicators will light up to indicate if the battery is fully charged (see “Charging the Battery” below and “Operator Controls”).

You must charge the batteries fully before using them for the first time.

Figure 2: Installing the Battery

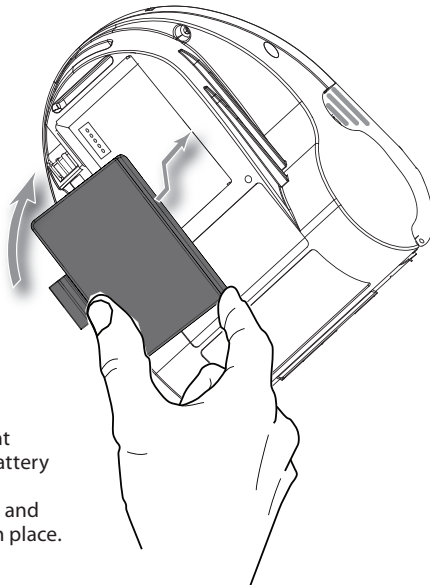

Insert the front edge of the battery in the battery compartment and lock the clip in place.

Figure 3: Removing the Battery

Press in on the locking clip to disengage the battery.

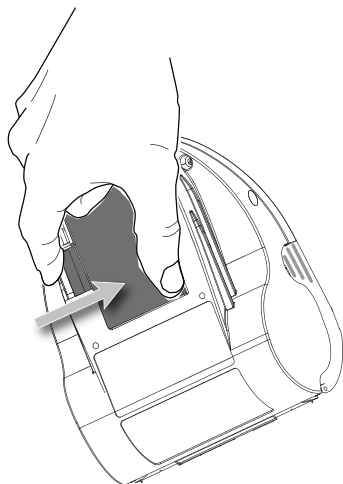

Lift up on the battery in the direction shown and remove from the battery compartment.

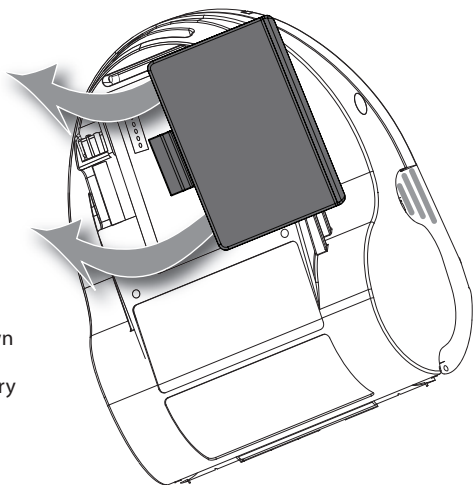

When the battery is first installed, the printer power and charge indicators should indicate the battery is not fully charged (see “Charging the Battery” below and “Operator Controls”).



You must charge the battery fully before using the printer for the first time.

Charging the Battery

Preparing the Power Supply

Before charging the battery for the first time, you must prepare the Power Supply. Refer to Figure 4 below:

Figure 4: Preparing the Power Supply

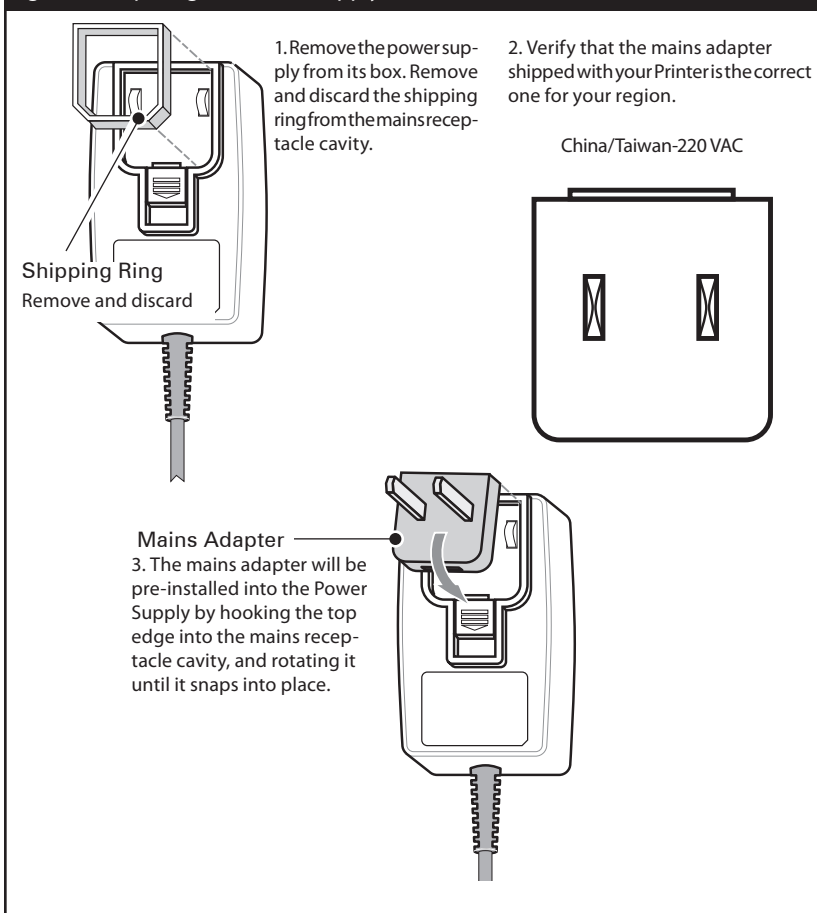

continued

Figure 5: Charging the Battery

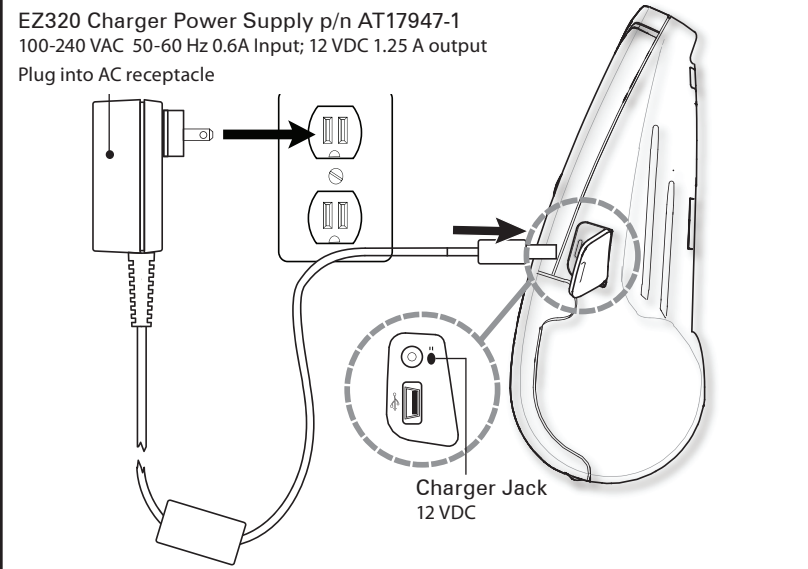

Charging the battery

Refer to Figure 5.

1. Plug the Charger Power Supply into the appropriate A.C. wall receptacle. Then insert the charge cable into the printer's charger jack.
2. The printer's charger indicator will indicate the status of the charger as follows:
 - An amber light indicates the battery is charging, and that the battery is less than 90% charged.
 - A green light indicates the battery is fully charged. The battery is ready for use.

Approximate Charge Times :

Batteries are fully charged after 2.5 hours from the low-battery shut-off state. Partially discharged batteries will take less time to charge.



NOTES: Use of the printer while charging will increase charge times. Charge times are for completely discharged batteries. As a safety feature the battery will stop charging after 4.5 hours regardless of the battery's charge state.

EZ320 Single Bay Charger

The Single Bay Charger is a charging system for use with the lithium-ion battery used in the EZ320 printer. The charger uses a 2 blade AC connector on the back of the charger that plugs into the wall outlet and will fully charge the battery in an average time of 2.5 hours.

Charging Status Indicators

The Single Bay Charger features two LED indicators, one green and one amber, which provide battery status to the user as described in the table below.

DC Power Input	Battery Status	Charging Indicator	Full Indicator
n/a	Battery Not Present	OFF	OFF
Present	Fully Charged	OFF	Green
Present	Charging	Amber	OFF

The amber LED will have battery charge icon  next to it to indicate that this is the charging status indicator. Likewise, the word "OK" will indicate that the green LED is the fully charged status indicator.

Figure 6: Docking Battery in Single Bay Charger



Battery Safety

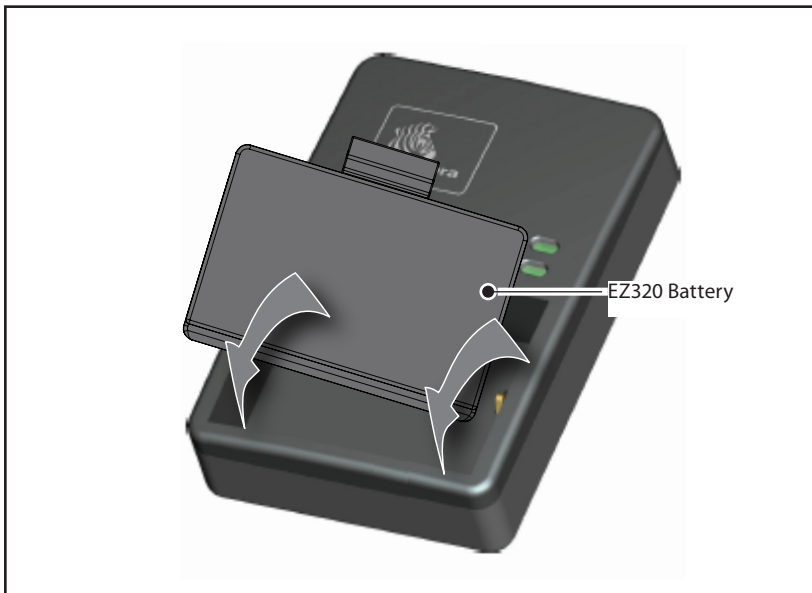

Caution • Avoid accidental short circuiting of any battery. Allowing battery terminals to contact conductive material will create a short circuit which could cause burns and other injuries or could start a fire.



Important • Always dispose of used batteries properly. Refer to Appendix D for more battery recycling information.



Caution • Use of any charger not approved specifically by Zebra for use with its batteries could cause damage to the battery pack or the printer and will void the warranty.



Read carefully and always observe the safety guidelines for Li-Ion batteries provided with each Battery Pack.

Charger Safety



Do not place the Single Bay Charger in locations where liquids or metallic objects may be dropped into the charging bay.

Loading the Media (80 mm)

1. Open the Media Cover (see Figure 7)
 - Firmly squeeze the Media Cover Tabs on either end of the Media Cover with your thumb and index finger. Pull up to open the Media Cover to reveal the media compartment.
2. Load the media (see Figure 8)
 - Insert the roll of media into the media compartment. Ensure that the media pulls off the core in the direction shown in Figure 8.
3. Close the Media Cover (see Figure 9)
 - Pull a short length of media out of the printer
 - Close the Media Cover firmly and ensure it is securely latched on both sides..
 - Press the Power button to turn on the printer and then press the Feed button. The printer will advance media until the Feed button is released. Verify the media is feeding properly and without binding or skewing sideways.

Figure 7: Opening the EZ320 Printer

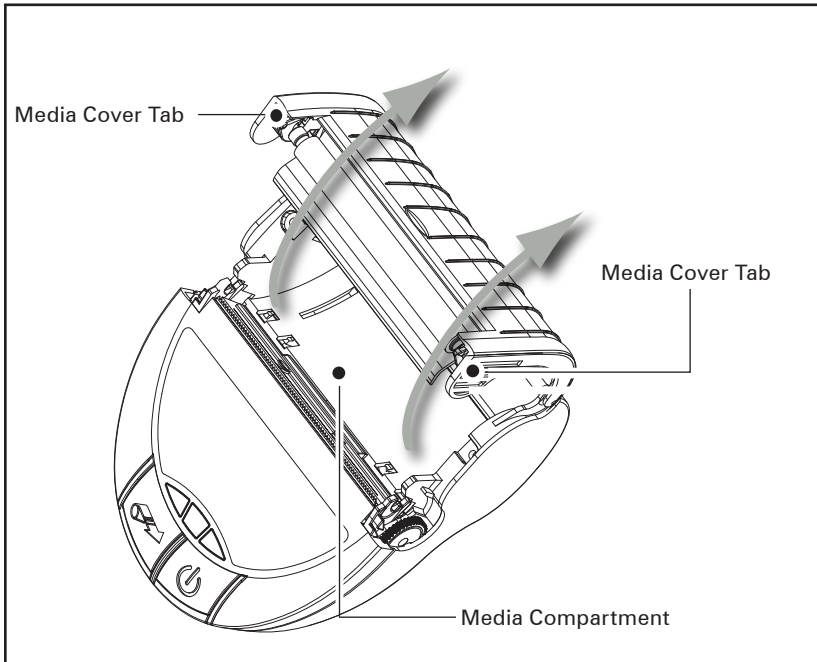

continued

Figure 8: Installing Media

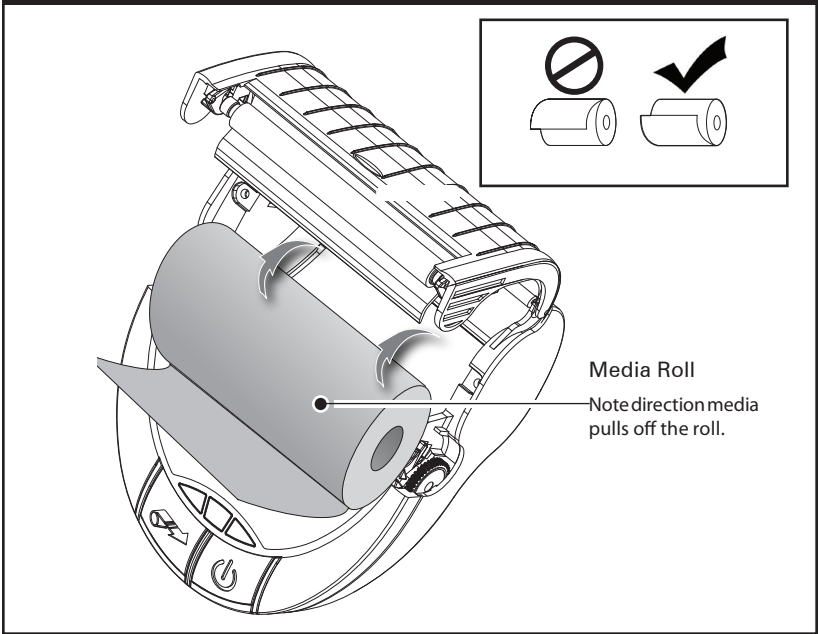
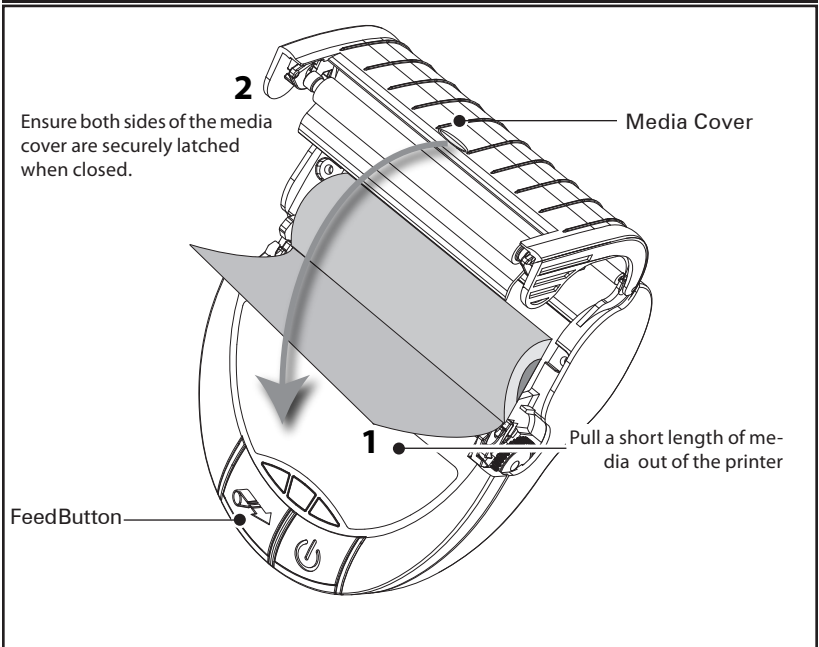

Figure 9: Closing the Media Cover



60 mm Roll of Media

The EZ320 printer also supports a 60 mm roll of media which requires the installation of two plastic media spacers. The media spacers are available through optional kit p/n P1031604. Contact Zebra Technologies for more information.

Media Black Bar Sensor

The EZ320 media black bar sensor default position for standard 80mm media is located on the right side of the media compartment when looking at the printer from the front (as shown below). There is also an alternate position for 80mm media on the left side and two (2) positions for 60mm media (one on the right side and one on the left). In all cases only one sensor position will be populated at a time. Which sensor position is populated is dependant on the size of the media and location of the black bar on the media. Descriptions of all four (4) positions are detailed below.

Figure 10: Black Bar Sensor Positions

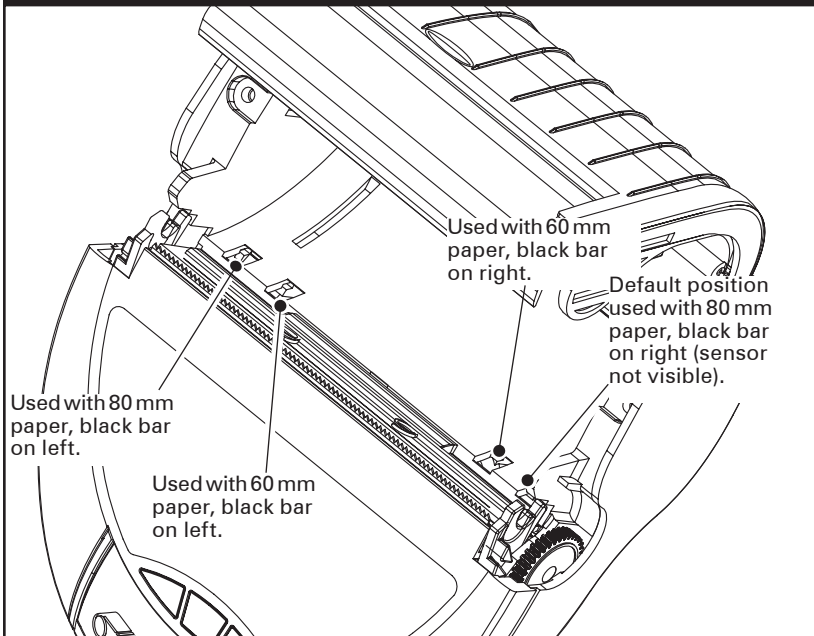

Operator Controls

EZ320 printer controls are detailed in Figure 11 on the following page.

The printer has two control buttons and four multipurpose indicators.

The Power Button turns the printer on and off.

The Feed Button advances a length of media until it is released.

The Green/Amber indicator to the left of the Power Button indicates the status of the printer's built-in charger:

- The indicator is off indicates the battery is not being charged.
- If the indicator is amber the battery is being charged.
- If the indicator is green, the battery is fully charged.

The Blue Bluetooth Indicator between the Power and Feed buttons has two states:

- A solid blue indicator means Bluetooth is connected and paired with no data transfer activity.
- A rapidly blinking blue light indicates a transfer of data.

The Amber Indicator to the right of the Feed button (Fig. 11) is an error indicator.

- An unlit indicator means there is no error condition and the printer can be used.
- A blinking (and beeping) indicator could mean one of three conditions exist, which will inhibit printer operation:
 1. There is no media loaded.
 2. The media cover is open.
 3. If both the above conditions are met and the error light is still flashing, there could be no firmware loaded in the printer, or the firmware could have become corrupted.

The Three Green LED's just above the product I.D. label is a battery status indicator.

- Three LED's lit represents 100% charge.
- Two LED's lit represents 66% charge.

- One LED lit represents 33% charge. This LED will be closest to the minus sign on the battery status icon and will blink and beep to alert the user of a low battery condition.

Figure 11: EZ320 Printer Controls

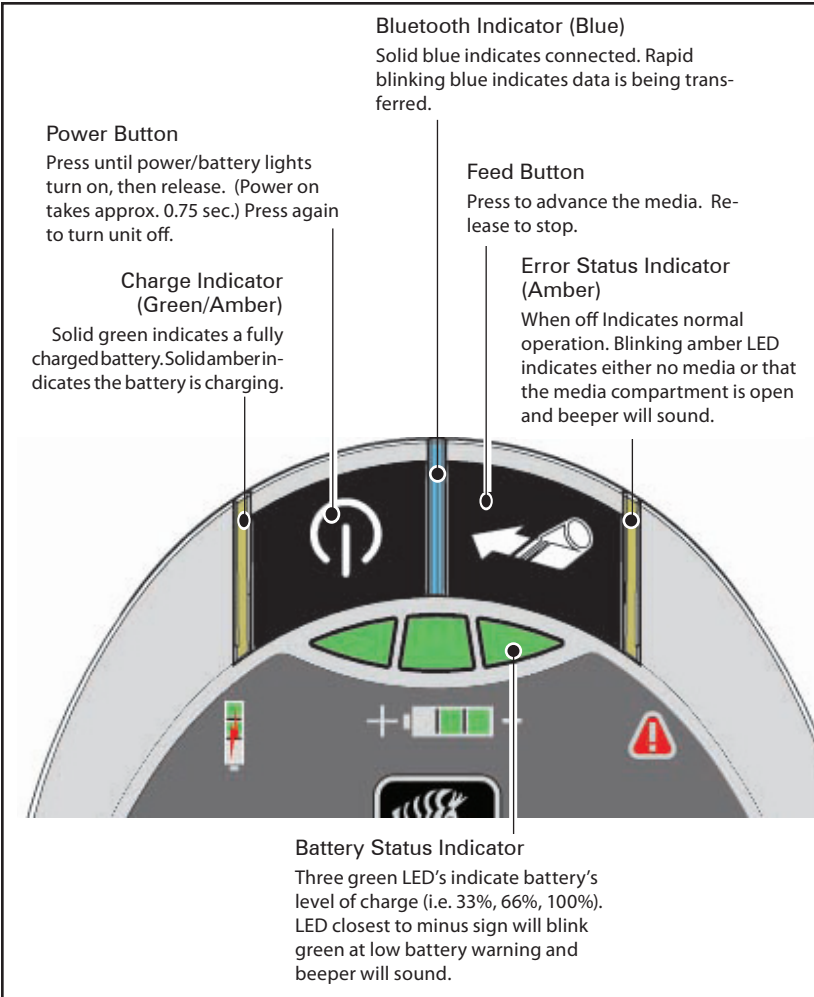

Verify the Printer Is Working

Before you connect the printer to your computer or portable data terminal, make sure that the printer is in proper working order. You can do this by printing a configuration label using the “two key reset” method. If you can’t get this label to print, refer to “Troubleshooting”.
Printing a Configuration Label

1. Turn the printer off. Load the media compartment with journal media (media with no black bars printed on the back)
2. Press and hold the Feed Button.
3. Press and hold the Power button and keep the Feed button pressed.
4. When the printer turns on and printing starts, release the Power button and then release the Feed button.

The unit will print a line of interlocking “x” characters to ensure all elements of the print head are working, print out the version of software loaded in the printer and then print two reports.

The first report indicates model, ROM version, serial number, etc. The second report prints approximately 10 seconds after the first report and prints out more detailed information on the printer’s configuration and parameter settings. If no second report appears, there is no application loaded. (See the Troubleshooting Section for sample printouts and a further discussion on how to use the configuration label as a diagnostic tool.)

Connecting the Printer

The printer must establish communications with a host terminal which sends the data to be printed. Communications occur in two basic ways:

- Via a cable using the USB 2.0 protocol. USB drivers are included in the Zebra DesignerDriver which can be downloaded from www.zebra.com.
- By means of a Bluetooth short range radio link.

Cable Communication

⚠ Caution • The printer should be turned off before connecting or disconnecting the communications cable.

The mini USB Type B connector on the cable plugs into the printer. The connectors are keyed to assure correct alignment; do not try to force the cable if it does not plug in. The standard USB Type A end of the cable must be plugged into the USB port on a computer as shown in Figure 12. The EZ320 utilizes the USB Open HCI interface driver allowing it to communicate with Windows® based devices.

USB drivers are included in the Zebra Designer Driver which can be downloaded from the Zebra Web site. Other terminals or communications devices may require the installation of special drivers to use the USB connection. Consult the manufacturer for further details.

Figure 12: Communications with a P.C.

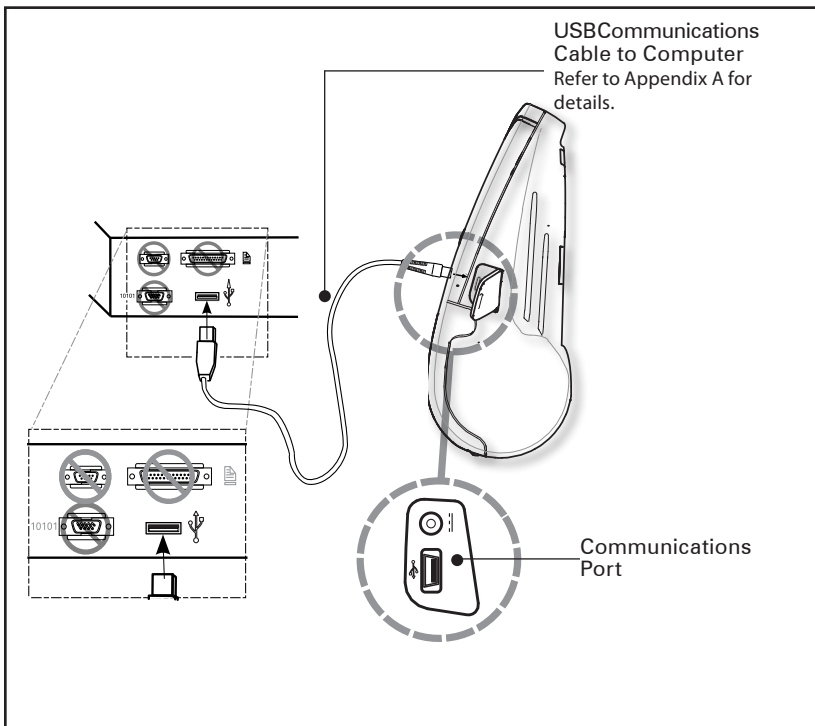

Wireless Communications with Bluetooth™

Bluetooth is a worldwide standard for the exchange of data between two devices via radio frequencies. Bluetooth radios are relatively low powered to help prevent interference with other devices running at similar radio frequencies. The range of a Bluetooth device is approximately 10 meters (32 feet). Both the printer and the device it communicates with must follow the Bluetooth standard.

Bluetooth Networking Overview

Each Bluetooth enabled EZ320 printer is identified by a unique Bluetooth Device Address (BDA) loaded into the printer when manufactured. The printer BDA can be obtained from the diagnostic report (see page 35). In order to exchange data, two Bluetooth enabled devices must establish a connection.

Bluetooth software is always running in the background, ready to respond to connection requests. One device (known as the master) must request a connection with another. The second device (the slave) then accepts or rejects the connection. A Bluetooth enabled EZ320 printer will act as a slave creating a Wireless Personal Area Network (WPAN) with the terminal sometimes referred to as a "piconet."

About Bluetooth Security

The Bluetooth radio in this printer complies with the Bluetooth specification 2.0 + EDR and therefore supports security modes 1, 2, and 3. The end user can select the security mode at which the printer will operate by configuring this parameter using Zebra Setup Utility (ZSU).

- Security Mode 1 is non-secure. Authentication and encryption functionality are bypassed. The printer is shipped with default Security Mode 1.
- Security Mode 2 is a secure mode that requires authentication and encryption. This is considered a service level-enforced security where security procedures are initiated after the LinkManager Protocol (LMP) is established. This is the host controller (radio module) responsibility and happens at the lower layers of communication including radio and baseband.

-
- Security Mode 3 is the more secure method supported, also called link level-enforced security. A device initiates security procedures before a physical link is fully established. Security Mode 3 mandates authentication and encryption for all connections to and from the device. In Security Mode 3, the printer is not discoverable.
 - Security Mode 4 is supported only by Bluetooth v2.1 + EDR. The EZ320 printer complies with Bluetooth v2.0 so it does not support Security Mode 4.

Certain Bluetooth parameters in the printer can be configured using Zebra Setup Utility (ZSU). ZSU can be downloaded free of charge from Zebra.com.

The Bluetooth settings that are configurable in the printer are: Authentication (ON/OFF), PIN (up to 16 digits), Discoverable (ON/OFF), Security Mode (1, 2, or 3 depending on the BT specification supported) and Friendly Name.

The printer default settings can be obtained from the diagnostic report (see page 35). The default “friendly name” of the printer is set as the printer’s serial number. The friendly name can be configured to any value by using ZSU. The EZ320 default Bluetooth Authentication is setpin and requires a PIN to be entered. The default PIN is 1234.

Carrying the Printer

Belt Strap

Refer to Figure 13 below for instructions on how to secure the belt strap to the printer and belt.

Figure 13: Using the Belt Strap

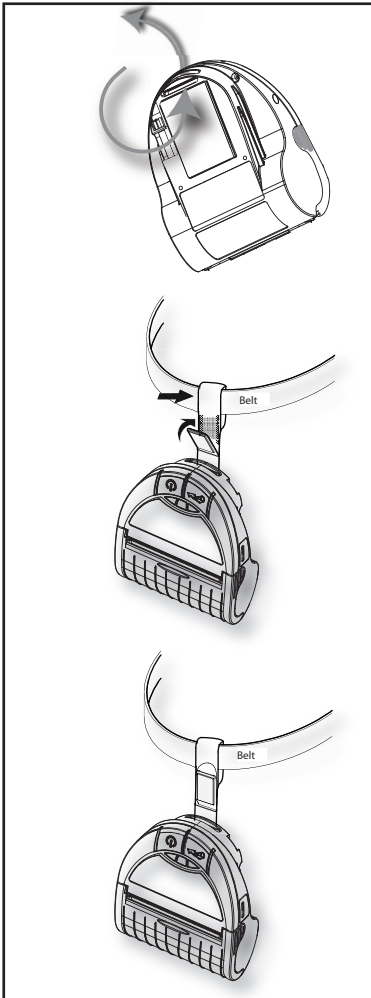

1) Insert the non-looped end of the belt strap through the slot in the bottom front of the printer.

2) Secure the non-looped end to other end of the belt strap using the two Velcro pads.

3) Slide the looped end of the strap over the belt as shown.

4) The printer should hang freely from the belt as shown.

Nylon Soft Case

The EZ320 printer also has the option of being used with a Nylon Soft Case (not included) which allows the user greater portability. The case loops onto a user's belt and provides access to the printer's paper path and printer controls. Use of the soft case is illustrated in Figure 14 below.

Figure 14: Using the Optional Soft Case

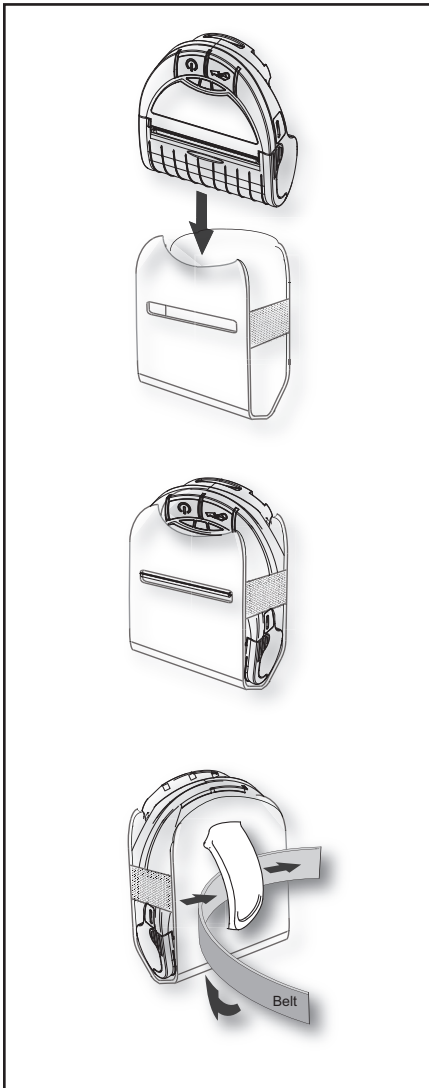

1) Slide the EZ320 printer into the soft case so that the paper exit path lines up with the opening on the case.

2) The belt is fed through the belt loop on the back of the soft case to secure in place.

Preventive Maintenance

Extending Battery Life

- Always observe the safety precautions in the Lithium-Ion Battery Technical Bulletin included with each Battery Pack.
- Never expose the battery to direct sunlight or temperatures over 60° C (140° F).
- Do not charge the battery when the temperature exceeds 45° C (113° F).
- Always use a Zebra power supply designed specifically for the EZ320 printers. Use of any other kind of power supply may damage the battery.
- Use the correct media for your printing requirements. An authorized Zebra re-seller can help you determine the optimum media for your application.
- If you print the same text or graphic on every label, consider using a pre-printed label.
- Choose the correct print darkness, and print speed for your media.



NOTE: The Tone setting can be modified via a Set/Get/Do command. Please refer to the CPCL Programming Manual at www.zebra.com/manuals for details.

- Remember that any rechargeable battery will lose its ability to maintain a charge over time. It can only be recharged a finite number of times before it must be replaced. Always dispose of batteries properly.
- If you print while charging the battery, charge times will be prolonged. Extensive printing while charging could deplete the battery enough to cause the low battery warning indicator to turn on. You should suspend printing at that time and allow the battery to re-charge completely.

continued

General Cleaning Instructions



Caution • To avoid possible personal injury or damage to the printer, never insert any pointed or sharp objects into the printer.

Always turn the printer off before performing any cleaning procedures.

Use care when working near the tear bar. The edges are very sharp.



Caution • The printhead can be very hot after prolonged printing. Allow it to cool off before attempting any cleaning procedures.



Only use the cleaning pen or a cotton swab saturated with alcohol for cleaning the printhead.



Caution • Use only cleaning agents specified in the following tables. Zebra Technologies Corporation will not be responsible for damage caused by any other cleaning materials used on this printer.

EZ320 Cleaning Instructions		
Area	Method	Interval
Printhead	Use a Zebra cleaning pen or a 70% Isopropyl alcohol solution on a cotton swab to clean the print elements from end to end (the print elements are located in the thin gray line on the printhead).	
Platen	Rotate the platen roller and clean it thoroughly with a Zebra cleaning pen or a 70% Isopropyl alcohol solution and a cotton swab.	After every five rolls of media (or more often, if needed)
Tear bar	Clean thoroughly with a Zebra cleaning pen or a 70% Isopropyl alcohol solution and a cotton swab.	
Exterior	Water dampened cloth	As needed
Media Compartment Interior	Brush/air blow.	After every five rolls of media (or more often, if needed)
Media/Black Bar Sensor		

Figure 15: EZ320 Cleaning

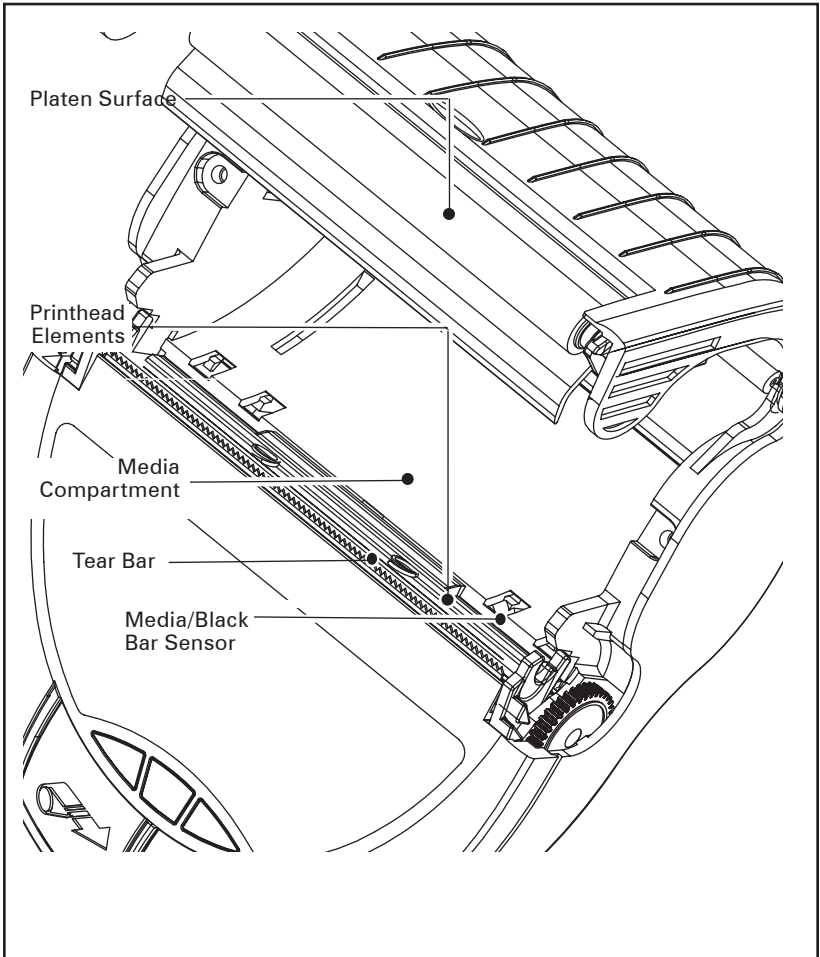

Note • Twelve packs of approved cleaning pens are available from Zebra as p/n AN11209-1.



Caution • To avoid possible personal injury or damage to the Printer, never insert any pointed or sharp objects into the Printer.

Troubleshooting

Interpreting Indicators

The printer's indicators display various printer functions and their status. Check the indicator status, then refer to the Troubleshooting topic referenced in the chart.

Function	Indicator Color	Indicator Status: Steady	Indicator Status: Blinking	Troubleshooting Topic
Battery Status Indicator	Green	Indicates printer is on and battery condition is OK to use.	One (of three) LED's blinks and printer beeps to signify Low Battery	3
Charger	Amber/ Green	Off indicates battery is not charging. Amber indicates battery is charging. Green indicates battery is charged.	N/A	1,6,10
Error	Amber	Off indicates no error condition.	No media or media door is open. Application may be missing or corrupted	2,4,7,9
Bluetooth	Blue	Bluetooth: Printer has paired with another Bluetooth device.	Solid blue indicates connected. Fast blinking indicates data is being received	5,8

Troubleshooting Topics

1. No power:

- Ensure you press and hold the Power switch until the Battery Status Indicator lights come on.
- Check that battery is installed properly.
- Recharge or replace battery as necessary.

2. Media does not feed:

- Be sure Media Cover is closed and latched.
- Check media compartment. Ensure media is not binding on the sides of the compartment.

3. Poor or faded print

- Clean printhead.
- Check battery for possible damage. Recharge or replace as necessary.
- Check quality of media.
- Check the "Tone" setting using Zebra Setup Utility.

-
4. Partial or missing print:
 - Check media alignment.
 - Clean printhead.
 - Ensure Media Cover is properly closed and latched.
 5. No print:
 - Replace battery.
 - Check cable to terminal.
 - (Bluetooth units only) Re-Pair Bluetooth connection with Master device.
 6. Reduced battery life:
 - Check battery date code — if battery is one to two years old, short life may be due to normal aging.
 - Recharge or replace battery.
 7. Flashing Amber indicator:
 - Check that media is loaded and that printhead is closed and securely latched.
 - If media is present and latch is closed, indicates that no application is present or application is corrupted. Program must be re-loaded.
 8. Communication Error:
 - (Bluetooth units only) Check that media is loaded, head is closed and blue communication link light is on.
 - (USB) Replace cable to terminal.
 9. Label Jam:
 - Open media cover.
 - Use Isopropyl alcohol to clean printer in area of jammed label.
 10. Battery Pack Is Hard to Install
 - Do not force the battery into place.
 - Verify you are seating the battery properly in the battery compartment.

Resetting an EZ320 Printer



If the printer has locked up and is not responding to any operator inputs or external commands from a connected terminal, you can perform a forced reset as follows:

1. Press and hold the power button for 5 seconds and then release. The printer will power down.
2. Re-start the Printer as usual. Any pending data in the printer will have been deleted and must be re-sent.

Determining Your Printer Version

The printer build date is identified by the Year and Week codes of the printer serial number label located on the bottom of the unit. (See Figure 16 below).

Figure 16: Determining Your Printer Version

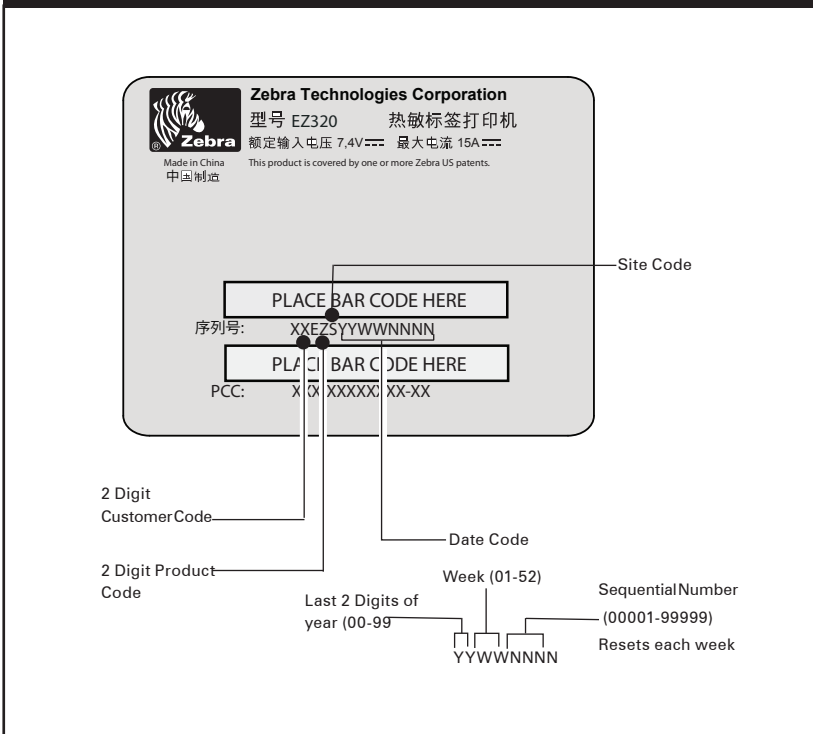

Troubleshooting Tests

Printing a Configuration Label

To print out a listing of the printer's current configuration follow these steps:

1. Turn the printer off. Load the media compartment with journal media (media with no black bars printed on the back)
2. Press and hold the Feed Button.
3. Press and hold the Power button and keep the Feed button pressed.
4. When the printer turns on, release the Power button, and once printing starts, release the Feed button.

Refer to Figures 17a, 17b, and 17c for a sample configuration printout.

Communications Diagnostics

If there is a problem transferring data between the computer and the printer, try putting the printer in the Communications Diagnostics Mode. The printer will print the ASCII characters and their text representation (or the period '.', if not a printable character) for any data received from the host computer

To enter Communications Diagnostics Mode:

1. Print a configuration label as described above.
2. At the end of 2nd diagnostics report, the printer will print: "Press FEED key to enter Diagnostics mode".
3. Press the FEED key. The printer will print: "Entering Diagnostics mode".



Note • If the FEED key is not pressed within 3 seconds, the printer will print "Diagnostics mode not entered" and will resume normal operation.

4. At this point, the printer is in Diagnostics mode and will print the ASCII hex codes of any data sent to it, and their text representation (or "." if not a printable character).

Additionally, a file with a ".dmp" extension containing the ASCII information will be created and stored in the printer's memory.

To terminate the Communications Diagnostics Mode and return the printer to normal operations:

1. Turn the printer OFF.
2. Wait 5 seconds.
3. Turn the printer ON.

Calling Technical Support

If the printer fails to print the configuration label, or you encounter problems not covered in the Troubleshooting Guide, contact Zebra Technical Support. Technical Support addresses and phone numbers for your area can be found in Appendix D of this manual. You will need to supply the following information:

- Model number and type (e.g. EZ320)
- Unit serial number (Found on the large label on the back of the printer, also found in the configuration label print-out. Refer to Figure 17a.)
- Product Configuration Code (PCC) (15 digit number found on the label on the back of the unit)

Figure 17a: Configuration Label Example

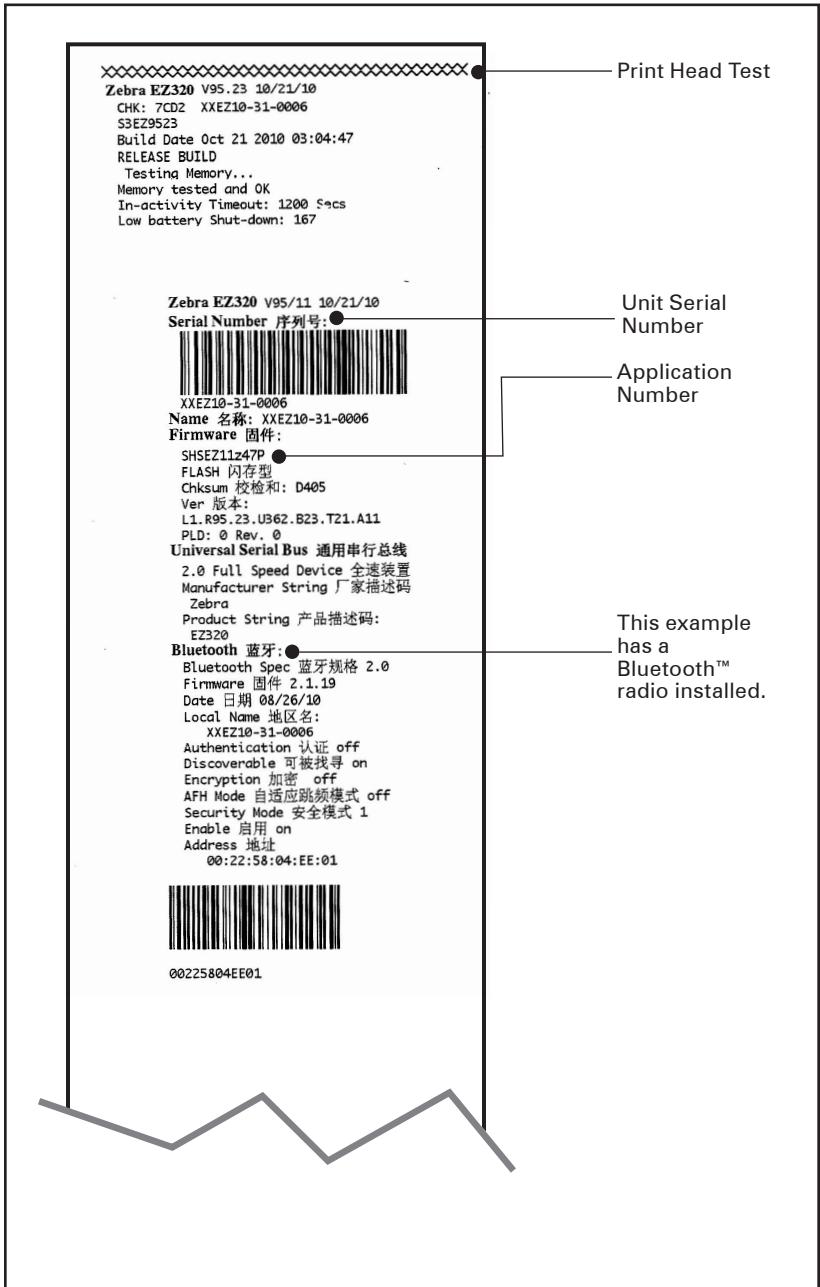
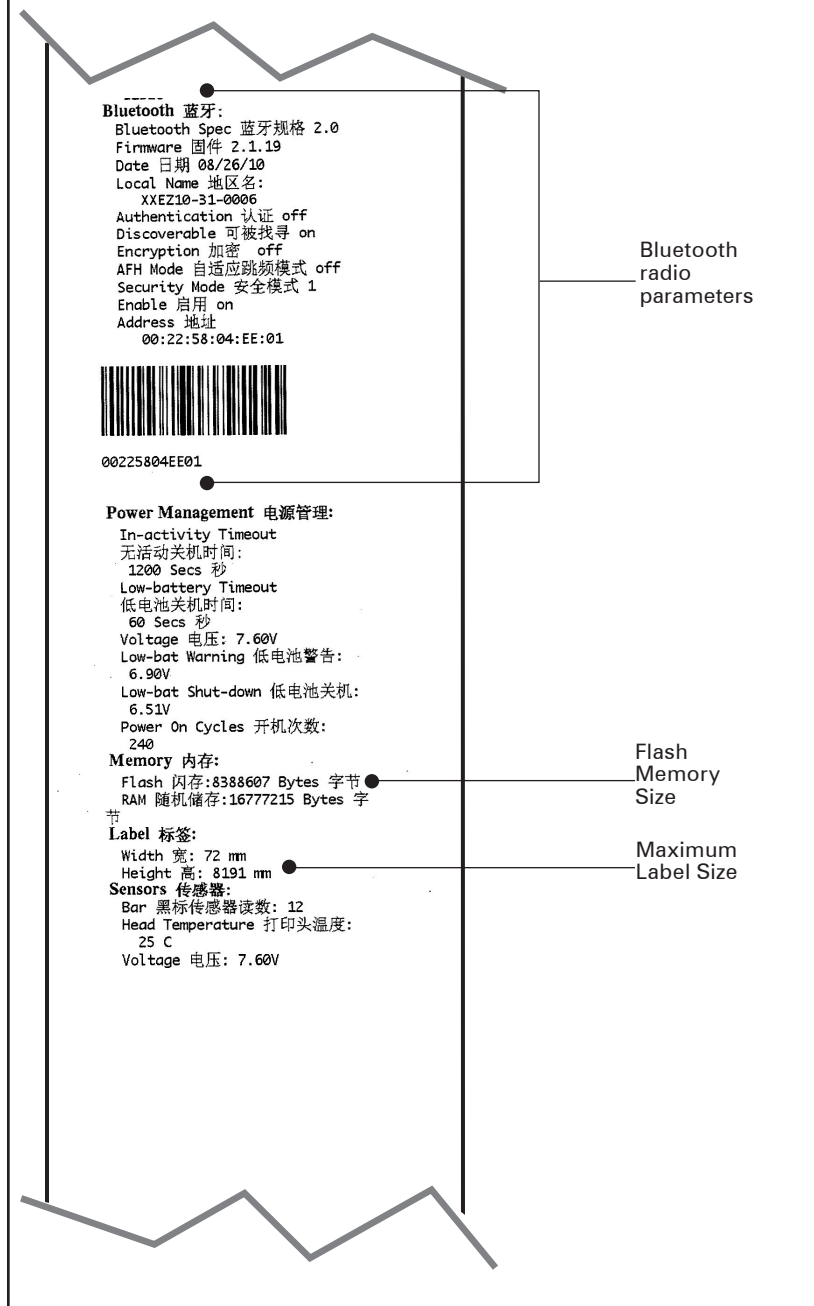
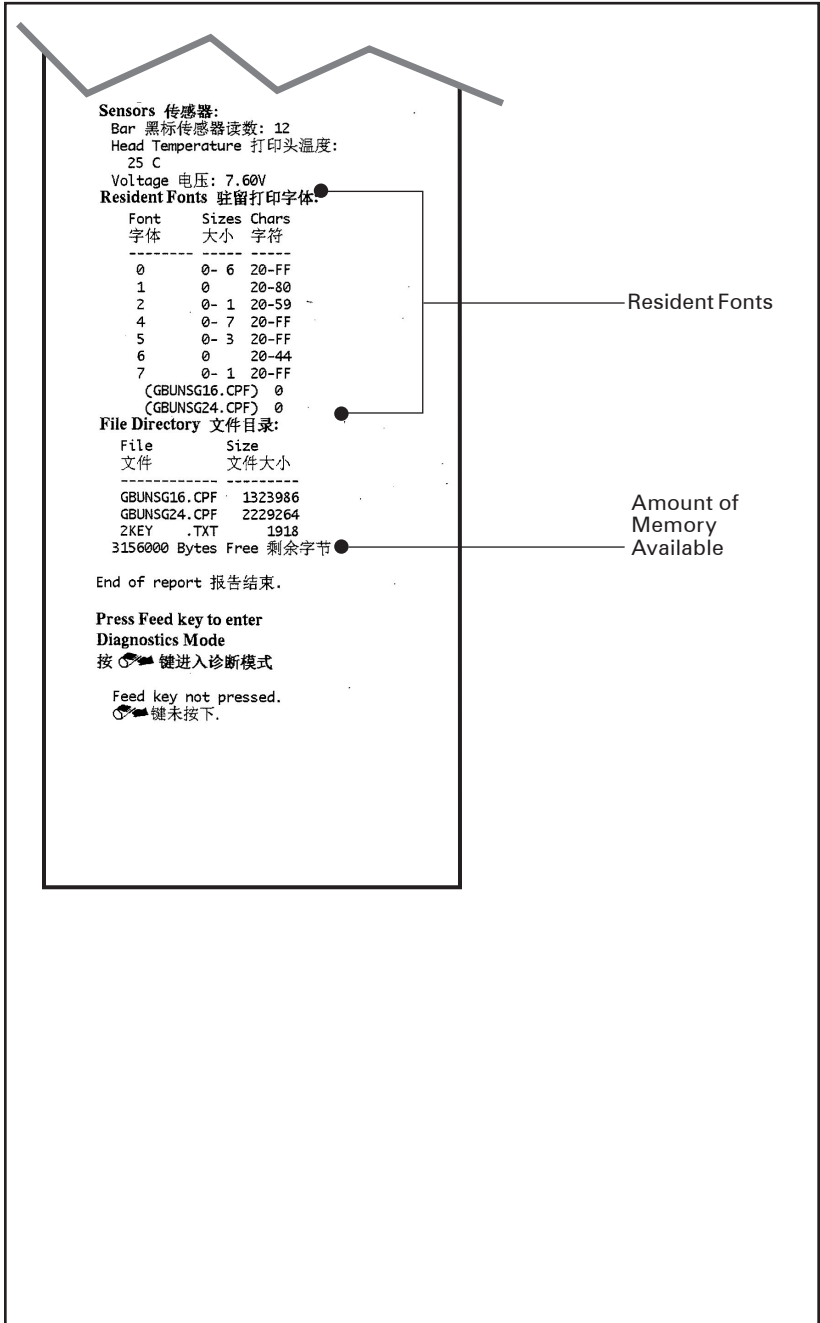

Figure17b: Configuration Label Example (continued)



continued

Figure 17c: Configuration Label Example (continued)



Specifications



Note.- Printer specifications are subject to change without notice.

Printing Specifications

Parameter	EZ320
Print Width	Fixed width 74,0 mm (2.91 in.)
PrintSpeed (typical)*	50,8 mm/second (2 in. per second)
Print Head Life, calculated	25400000 mm (1 million inches) of media fed
Print Density	8 dots/mm (203 dots/inch)
Printhead Burn Line to Tear Edge	5,0 mm (.197 in.)

* Extreme temperatures and print densities may affect print speed. Please contact Zebra for guidance to maximize the performance of your solution.

Memory and Communications Specifications, EZ320

Flash Memory	8 MB
SRAM	16 MB
Standard Communications	USB 2.0 Full Speed Interface (12 Mbps) Standard Bluetooth compliant with Bluetooth specification 2.0

Media Specifications

Parameter		EZ320
Width		80,0 mm \pm 1 mm (3.15 in. \pm 0.03 in.)
Max. Printable Area	Width	74,0 mm (2.91 in.)
	Length	14,5 mm (.57 in.) min. to 813 mm (32 in.) max
Media Thickness		0.060 mm to 0.1143 mm (.0023 in to .0045 in)
Max. Media Roll dia.		42,0 mm (1.65 in.) O.D.
Label Inner Core Diameter		10,2 to 19,0 mm (0.40 to 0.75 in.)
Black Mark Dimensions		The reflective media black marks should extend from the right side of the roll on the front side of the media. Minimum mark width: 7 mm (0.28 in.) perpendicular to edge of media, starting from the right edge of the roll when looking at the print side of the media. Mark length: 3,0-11,0 mm (0.12 - 0.43 in.) parallel to edge of the roll. (See illustration below).

Black Mark Dimensions)

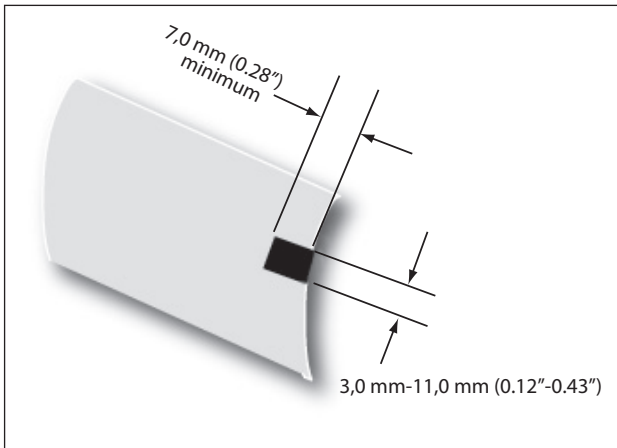

Font and Bar Code Specifications for EZ320

Linear & 2-D Bar Bar Codes Available	Codabar (NW-7)
	UCC/EAN 128
	UCC composite A/B/C
	Code 39
	Code 93
	Code 128
	EAN 8, 13, 2 and 5 digit extensions
	EAN-8 composite
	EAN 13 composite
	Interleaved 2 of 5
	MSI/Plessey
	FIM/POSTNET
	Intelligent Mail Barcode
	UPC-A, 2 and 5 digit extensions
	UPC-E, 2 and 5 digit extensions
	UPC-A composite
	UPC-E composite
	QR Code
	MaxiCode
	PDF 417
	GS1 DataBar (RSS-14)
	GS1 DataBar (RSS-14) expanded
	GS1 DataBar (RSS-14) truncated
GS1 DataBar (RSS-14) limited	
GS1 DataBar (RSS-14) stacked	
GS1 DataBar (RSS-14) stacked omnidirectional	
Aztec	
Rotation Angles	0°, 90°, 180°, and 270°

continued

Fonts Available	GBUNSG24.CPF Simplified Chinese 24x24 GBUNSG16.CPF Simplified Chinese 16x16 CTUNMK24.CPF Traditional Chinese 24x24
-----------------	--

Note: GB-18030 and BIG5 both support ASCII character sets.

The default EZ320 Encoding is GB-18030. To print Traditional Chinese, use ENCODING BIG5 command. See below for font and encoding selection as well as examples.

Pre-loaded Fonts

1. GBUNSG24.CPF

- Description: Simplified Chinese 24x24
- Encoding Command: GB18030 (default)
- Example (Label Mode):
! 0 200 200 300 1
ENCODING GB18030
TEXT GBUNSG24.CPF 0 10 50 add text here. . .
PRINT
- Example (Line-print Mode):
! U1 ENCODING GB18030
! U1 SETLP GBUNSG24.CPF 0 24
add text here, line 1
add text here, line 2

2. GBUNSG16.CPF

- Description: Simplified Chinese 16x16
- Encoding Command: GB18030 (default)
- Example (Label Mode):
! 0 200 200 300 1
ENCODING GB18030
TEXT GBUNSG16.CPF 0 10 50 add text here. . .
PRINT
- Example (Line-print Mode):
! U1 ENCODING GB18030
! U1 SETLP GBUNSG16.CPF 0 24
add text here, line 1
add text here, line 2

3. CTUNMK24.CPF

- Description: Traditional Chinese 24x24
- Encoding Command: BIG5
- Example (Label Mode):

```
! 0 200 200 300 1
ENCODING BIG5
TEXT CTUNMK24.CPF 0 10 50 add text here. . .
PRINT
```
- Example (Line-print Mode)

```
! U1 ENCODING BIG5
! U1 SETLP CTUNMK24.CPF 0 24
add text here, line 1
add text here, line 2
```

*SimSun is provided under license from Ascender Corporation. SimSun is copyright ZHONGYI Electronic and Microsoft Corporation.

USB Communications Port

Pin#	Signal Name	Type	Description
1	VBUS	-	USB Bus Power
2	USB -	bi-directional	I/O signals
3	USB +	bi-directional	I/O signals
4	USB_ID	-	Identifies A/B connector
5	Return	-	Ground

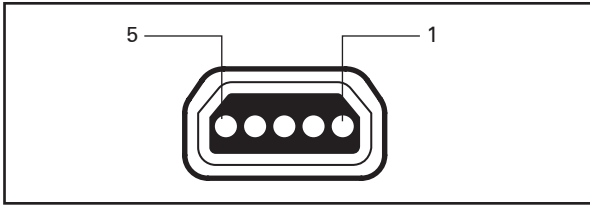
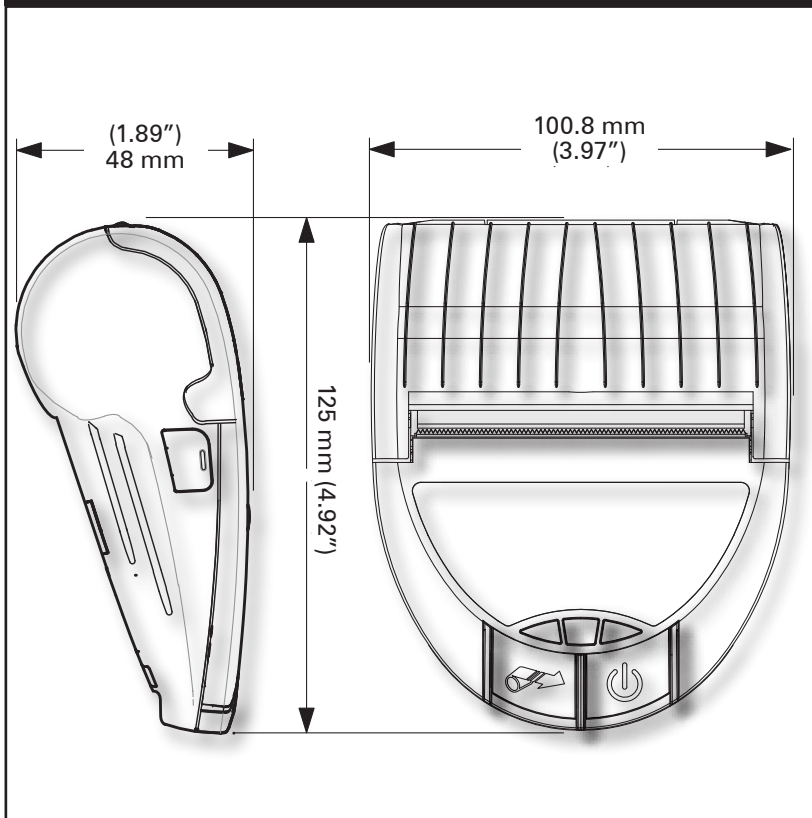

Figure 18: USB Communications Port

Physical, Environmental and Electrical Specifications

Parameter	EZ320
Weight w/ battery, excluding media	295g. (.65 lbs.)
Temperature	Operating : -10° to 50° C (14° to 122° F)
	Charging: 0° to 40° C (32° to 104° F)
	Storage w/o battery: -25° to 60° C (-4° to 140° F)
	Storage w/ battery: -25° to 45°C (-4° to 113° F)
Relative Humidity	Operating: 10% to 90% (non- condensing)
	Storage: 10% to 90% (non- condensing)
Battery	Lithium-Ion 2S-1P, 7.4VDC (nominal); 1150 mAHr.
Printer Input Power	12.0 VDC \pm 10%; 2A max
Ingression Protection (IP) Rating	42

Figure 19: EZ320 Overall Dimensions



EZ320 Accessories

Description
Adjustable belt strap p/n P1033361 (included)
Protective carrying case P1033362 (optional)
AC Adapter AT17947-1 (included)
Extra battery packs (p/n P1026078)
Single bay battery charger (optional)



Refer to Appendix A for information on Data I/O Cables

For more details on available accessories, contact your authorized Zebra re-seller.

Appendix A

Interface Cables

USB Cable

Part Number AT17010-1; USB A to USB Mini B Cable

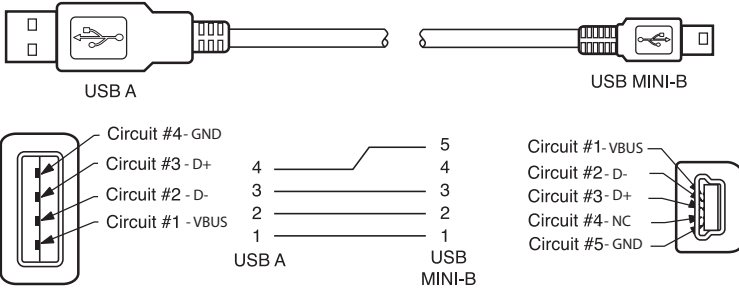

MORE INTERFACE CABLES



Contact the Factory or your Zebra Sales Representative for more information on interface cables to most major manufacturer's data terminals.

You may also visit the Zebra Web site at <http://www.zebra.com> for a listing of interface cables for all series of Zebra mobile printers

Appendix B

Maintenance Supplies

In addition to using quality media provided by Zebra, it is recommended that the printer be cleaned as prescribed in the maintenance section. The following items are available for this purpose:

- Cleaning Pen (12 pack), Reorder No. AN11209-1
- Cleaning Pads (10 pack), Reorder No. AN11207-1

Appendix C

Media Supplies

Please make sure that the media supplies used in the EZ320 conform to the specifications listed below for the printer.

The different media types outlined in the following table were tested and verified to work properly in the EZ320.

EZ320 Media

Description	Weight	Width	Thickness	Roll OD	Core OD
Non-topcoated direct thermal receipt paper	60g/m ²	80 mm +/- 1 mm	0.058 mm	40 mm	12.7 mm
Non-topcoated direct thermal receipt paper	100g/m ²	80 mm +/- 1 mm	0.086 mm	40 mm	12.7 mm
Non-topcoated direct thermal receipt paper, black bar	100g/m ²	80 mm +/- 1 mm	0.086 mm	40 mm	12.7 mm
Topcoated direct thermal receipt paper	80g/m ²	80 mm +/- 1 mm	0.081 mm	40 mm	12.7 mm
Direct thermal polypropylene receipt, perforations	80g/m ²	80 mm +/- 1 mm	0.081 mm	40 mm	12.7 mm
Non-topcoated direct thermal receipt paper, black bar	100g/m ²	60 mm +/- 1 mm	0.086 mm	40 mm	12.7 mm
Direct thermal polypropylene receipt, non-perforated	80g/m ²	60 mm +/- 1 mm	0.081 mm	40 mm	12.7 mm

Appendix D

Product Support

When calling with a specific problem regarding your printer, please have the following information on hand:

- Model number/type (e.g. EZ320)
- Unit serial number
- Product Configuration Code (PCC)

For Product Support Contacts, see the table on the next page or contact your local re-seller.

EZ320 Serial Number Label

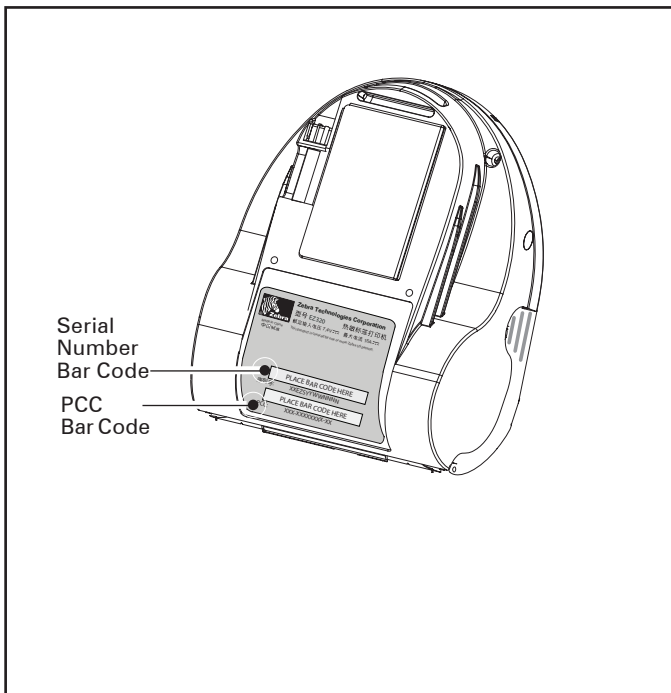

Product Support Contacts

In the Asia Pacific region contact

Regional Headquarters	Technical Support	Customer Service
Zebra Technologies Asia Pacific, LLC 120 Robinson Road #06-01 Parakou Building Singapore 068913 T: +65 6858 0722 F: +65 6885 0838	T: +65 6858 0722 F: +65 6885 0838 E: tsasiapacific@zebra.com	For printers, parts, media, and ribbon, please call your distributor, or contact us. T: +65 6858 0722 F: +65 6885 0837
Regional Office	Technical Support	Customer Service
Beijing China Regional Office Room 2103/2105 Global Trade Center Tower A 36 North Third Ring Road East Dongcheng District Beijing 100013, P.R. China T: +86 10 5825 7428 F: +86 10 5825 7429	T: +65 6858 0722 F: +65 6885 0838 E: tschina@zebra.com	For printers, parts, media, and ribbon, please call your distributor, or contact us. T: +65 6858 0722 F: +65 6885 0837
Guangzhou China Regional Office Room 3318, 33/F Office Tower China shine Plaza, 9 Linhexi Road Tianhe District, Guangzhou 510610, P.R.C. T: +86 20 3810 7798 F: +86 20 3810 7783	T: +65 6858 0722 F: +65 6885 0838 E: tschina@zebra.com	For printers, parts, media, and ribbon, please call your distributor, or contact us. T: +65 6858 0722 F: +65 6885 0837
Shanghai China Office Room 2308-2312 Plaza66 Tower2 1366 Nanjing Road(w) Shanghai 200040, P.R. China T: +86 21 5175 8558 F: +86 21 6288 8393	T: +65 6858 0722 F: +65 6885 0838 E: tschina@zebra.com	For printers, parts, media, and ribbon, please call your distributor, or contact us. T: +65 6858 0722 F: +65 6885 0837

Appendix E

Product Documentation

Please refer to Zebra's web site (see below) at www.zebra.com.cn/products for finding specific product documentation and software downloads for the EZ320 printer.

The screenshot shows the Zebra website interface. At the top left is the Zebra logo and the slogan '用于改善业务的打印方案' (Printing solutions for improving business). A search bar and a language dropdown menu are located at the top right. Below the header is a navigation menu with tabs for '行业解决方案', '产品', '如何购买', '驱动程序和下载', '服务和支持', '资源库', '关于Zebra', and '合作伙伴'. The main content area features a large banner image of a person using a printer in a warehouse setting. To the right of the image is a yellow box with the text '产品 Zebra 坚固耐用、小巧紧凑的打印机及其它创新产品为专业打印确立了标准'. Below the banner are three columns: '打印机' (Printers) with a list of printer types and a dropdown menu for selecting a model; '更多的 Zebra 产品' (More Zebra Products) with a list of accessories and features; and '如何购买' (How to Buy) with a '联系我们' (Contact Us) link. At the bottom, there is a footer with copyright information and a link to the Zebra card printer page.

continued

Index

A

- Accessories
 - Belt strap 25
 - Soft case 26
 - list of 45

B

- Battery, charging 12
- Battery, installing 10
- Battery life, tips for extending 27
- Battery, removing 11
- Bluetooth Device Address (BDA) 23
- Bluetooth™ Networking Overview 23

C

- Cleaning
 - general instructions 29
- Communications
 - USB
 - Connector signals 43
 - with a cable 22
- Communications diagnostics 33
- Configuration Label
 - printing 34

D

- Damage, shipping 7

M

- Manual
 - CPCL Programming 7
- Media
 - loading 80 mm 16
 - 60 mm 18
 - black bar sensors 18

O

- Operator Controls 19

P

- Programming language
 - CPCL 7

S

- Safety Precautions
 - placement of charger 15
- Single Bay Charger 14
- Specifications

- Font/bar Code 40
- Media 39
- Memory/communications 38
- Physical 43
- printing 38

T

- Technical Support, contacting 34
- Troubleshooting
 - Communications Diagnostics Mode 33
 - control panel indicators 30
- Troubleshooting tests 33
 - printing a configuration label 21,33
 - EZ320 configuration label example 35,36,37
- Troubleshooting Topics 31

W

- Wireless communications
 - Bluetooth™ radio 23

Patent Numbers

This product and/or its use may be covered by one or more of the following US patents and corresponding international patents worldwide

D275,286	5,029,183	5,367,151	5,552,592	6,068,415
D347,021	5,047,617	5,372,439	5,570,123	6,068,415
D389,178	5,103,461	5,373,148	5,578,810	6,095,704
D430,199	5,113,445	5,378,882	5,589,680	6,109,801
D433,702	5,140,144	5,396,053	5,612,531	6,123,471
D549,768	5,132,709	5,396,055	5,642,666	6,147,767
3,964,673	5,142,550	5,399,846	5,657,066	6,151,037
4,019,676	5,149,950	5,408,081	5,768,991	6,201,255 B1
4,044,946	5,157,687	5,410,139	5,790,162	6,231,253 B1
4,360,798	5,168,148	5,410,140	5,791,796	6,261,009
4,369,361	5,168,149	5,412,198	5,806,993	6,261,013
4,387,297	5,180,904	5,415,482	5,813,343	6,267,521
4,460,120	5,229,591	5,418,812	5,816,718	6,270,072 B1
4,496,831	5,230,088	5,420,411	5,820,279	6,285,845 B1
4,593,186	5,235,167	5,436,440	5,848,848	6,292,595
4,607,156	5,243,655	5,444,231	5,860,753	6,296,032
4,673,805	5,247,162	5,449,891	5,872,585	6,364,550
4,736,095	5,250,791	5,449,893	5,874,980	6,379,058 B1
4,758,717	5,250,792	5,468,949	5,909,233	6,409,401 B1
4,816,660	5,262,627	5,479,000	5,976,720	6,411,397 B1
4,845,350	5,267,800	5,479,002	5,978,004	6,428,227 B2
4,896,026	5,280,163	5,479,441	5,995,128	6,530,705
4,897,532	5,280,164	5,486,057	5,997,193	6,540,122
4,923,281	5,280,498	5,503,483	6,004,053	6,607,316
4,933,538	5,304,786	5,504,322	6,010,257	6,609,844
4,992,717	5,304,788	5,528,621	6,020,906	6,874,958
5,015,833	5,321,246	5,532,469	6,034,708	6,899,477
5,017,765	5,335,170	5,543,610	6,036,383	
5,021,641	5,364,133	5,545,889	6,057,870	



www.zebra.com

Zebra Technologies Corporation
475 Half Day Road, Suite 500
Lincolnshire, IL 60069
Phone: 1.847.634.6700 or 1.800.423.0442
Fax: 1.847.913.8766